

Percussive Tools & Others

PERCUSSIVE TOOLS & OTHERS

RIVETING HAMMERS

BRH series compact riveting hammers present fast riveting work of small size rivets on aluminum, duralumin plates. Optimum for assembly of aircrafts, automobiles, vehicles, and various other industrial machines.



BRH-3
-3-X1

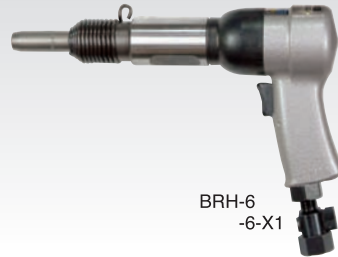

BRH-6
-6-X1

Model	Inlet shape	Riveting Capacity mm(in)		Blows Per Min. B.P.M	Piston Dia. x Stroke mm(in)	Load Air Consumption (Approx.) l/min(ft ³ /min)	Overall Length (about) mm(in)	Net Weight kg(lb)	Air Inlet Thread (Pipe Thread) Rc	Air Hose Size mm(in)	Air Pressure MPa(lb/in ²)
		Steel	Duralumin								
BRH-3	Round	2.4(3/32)	3.2(1/8)	3600	14.3X38(9/16X1.5)	400(14.1)	135(5.3)	1.10(2.4)	1/4	9.5(3/8)	0.6(85)
BRH-6	Round	4.8(3/16)	6.4(1/4)	3500	20X60(25/32X2.4)	400(14.1)	200(7.9)	1.35(3.0)	1/4	9.5(3/8)	0.6(85)
※BRH-6A	Round	4.8(3/16)	6.4(1/4)	1600	12.7X101(1/2X4)	370(13.1)	209(8.2)	1.35(3.0)	1/4	9.5(3/8)	0.6(85)
BRH-3-X1	Hexagon	2.4(3/32)	3.2(1/8)	3600	14.3X38(9/16X1.5)	400(14.1)	135(5.3)	1.10(2.4)	1/4	9.5(3/8)	0.6(85)
BRH-6-X1	Hexagon	4.8(3/16)	6.4(1/4)	3500	20X60(25/32X2.4)	400(14.1)	200(7.9)	1.35(3.0)	1/4	9.5(3/8)	0.6(85)

Standard accessories: (BRH-3,6,3-X1,6-X1) 1 regulator, 1 snap, 1 snap buffer A, 1 hose nipple. (BRH-6A) 1 regulator, 1 snap buffer A, 1 hose nipple.

SNAPS (Attachments)

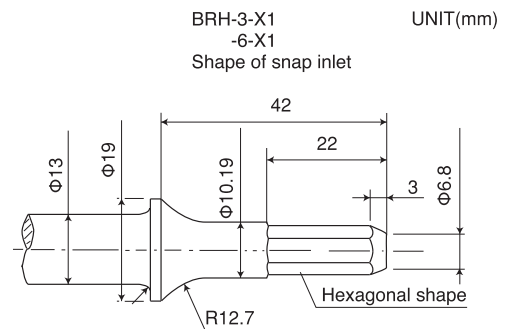
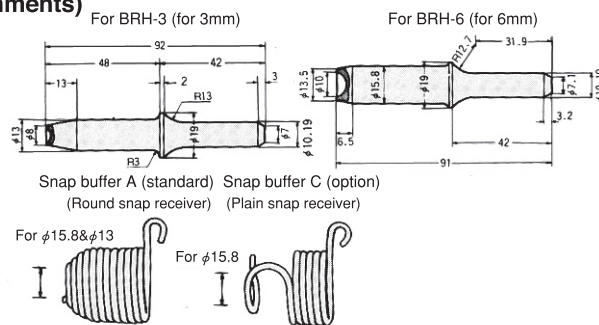

AUTO CUTTERS

This tool can be applied to various uses by easily changing the chisels with different shapes according to works such as separation of spot welded point, removal of scale, cut off rivet, etc.

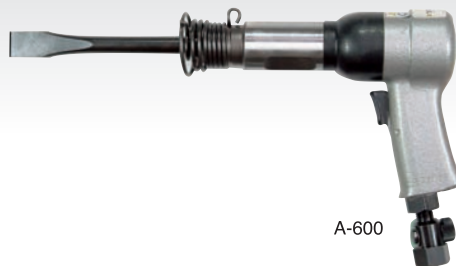

A-600

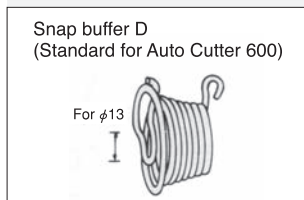

Model	Blows Per Min. B.P.M	Piston Dia. x Stroke mm(in)	Load Air Consumption (Approx.) l/min(ft ³ /min)	Overall Length (about) mm(in)	Net Weight kg(lb)	Air Inlet Thread (Pipe Thread) Rc	Air Hose Size mm(in)	Air Pressure MPa(lb/in ²)
A-600	3500	20X60(25/32X2.4)	400(14.1)	200(7.9)	1.40(3.1)	1/4	9.5(3/8)	0.6(85)

Standard accessories: 5 chisels, 1 regulator, 1 snap buffer D, 1 hose nipple.

A600 Standard Chisels



#602 Flat chisel
Cut off bolts and nuts, pins.
Separation of spot welded point.



#607 Rivet cutting chisel
Cut off rivet.
Shearing of spot welded point.



#603 Seat metal chisel A
Cut off seat metal.
Cut off vehicle's body panel.



#612 Bend chisel
Chipping of painting.
Separation of spot welded point.



#604 Seat metal chisel B
Cut off seat metal.
Cut off vehicle's body panel.

FASTENING TOOLS

DRILLS AND TAPPERS

GRINDERS

PERCUSSIVE TOOLS AND OTHERS

RECOMMENDED PRODUCTS