

Specifications

Product code	Throttle type : GR-M58(75)KS Lever type : GR-M58(75)KL
Grinding wheel diameter	58×3.5×9.53 mm 75×4×9.53 mm
Use pressure	0.6 MPa(6kgf/cm ²)
Air consumption	0.54 m ³ /min
No load speed of revolutions	12,500 min ⁻¹
Body mass ※Including Safety guard for 58mm and wheel nut for 2 1/4 wheel	Throttle type : 0.54 kg Lever type : 0.59 kg
Full length	160 mm
Diameter of grip part	36 mm
Swich method	Throttle type or Lever type
Noise	85 dB

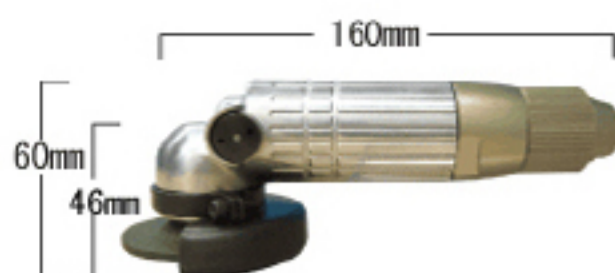

Part list, tool diagram

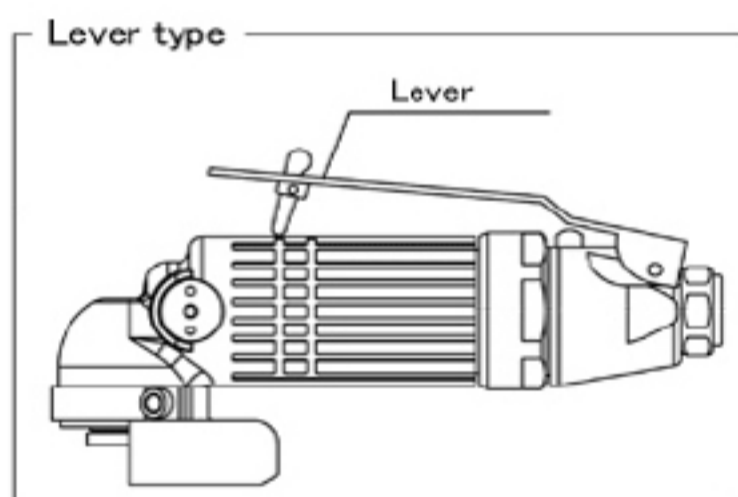
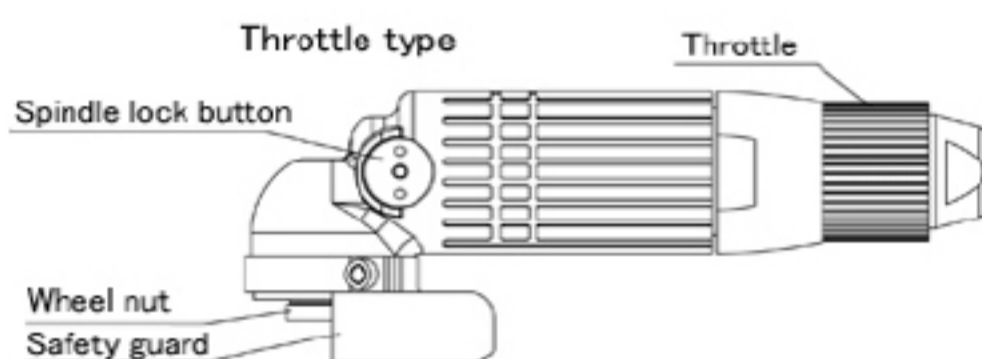

Article



Throttle type



Lever type

Package

